

Radiopharmacy Compounding Equipment



PRODUCTS OVERVIEW

ESCO FRONTIER® RADIOISOTOPE FUME HOOD

- Provides operator and environment protection
- Operator is protected from radiation by incorporating lead-shielded front sliding sash and L-block shield.



LEAD-SHIELDED BIOSAFETY CABINET

- Facilitates an ISO Class 5 working environment for
- Provides product, operator, and environment protection
- Operator is protected from radiation by lead-shielded sides, work zone bottom, and front sliding sash

CYTOCULTURE® LEAD-SHIELDED BIOLOGICAL SAFETY CABINET

- Provides protection to user, environment and product
- Operator is protected from radiation by incorporating lead-shielded front sliding sash and L-block shield.





RADIOISOTOPE DISPENSING ISOLATOR

- Negative pressure, single pass isolator
- Designed in compliance to USP <797> and USP <825>
- Consists of elution process chamber and pass-through chamber
- Capable of carrying out manual pressure decay test
- Integrated with generator and dose calibrator



3

GMP-COMPLIANT RADIOISOTOPE DISPENSING ISOLATOR

- Complete design compliance to PIC/S and GMP, for dispensing of generator-produced radioisotopes.
- Capable of automated pressure hold test and glove leak testing
- Integrated with BioVap™ Biodecontamination System
- Integrated with generator, dose calibrator, and radiation monitoring system

Esco Frontier[®] Radioisotope Fume Hood

Superior Protection for Radioisotope Laboratories

The **Esco Radioisotope Fume Hood** is designed for radiopharmaceutical dispensing and protects the operator during dispensing and QC checks involving radioisotopes.

ISOCIDE™

Esco ISOCIDE™ antimicrobial coating on all painted surfaces minimizes microbial contamination

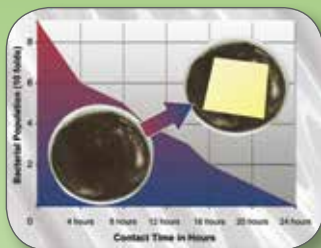

Modular Design

Modular and easily customized with your desired equipment integrated inside the workstation

Sentinel™ XL Airflow Monitor Alarm (Optional)

An airflow monitoring device designed to monitor real time face velocity.

Bag In Bag Out (BIBO) Filters

Hood air is being filtered via two filters, HEPA and carbon filters to ensure safety

Other key features:

- Radiation proof acrylic glass with lead equivalence
- Quiet, energy-efficient fan; motor unit auto-adjusts to compensate for filter blockage
- Interior walls are made of 316L stainless steel for maximum corrosion resistance
- With integrated dose calibrator reader out and shielded generator system

Other Radiation Shielding Components

L-block shields feature seamless 304 brushed stainless steel exteriors



Shielded waste containers typically have 5, 10, 15, 30-gallon capacity, but any capacity you specify can be accommodated

Ensured Protection from Radiation

Pb-shielding on cabinet front, sides, and work zone bottom based on client's needs and required specifications



Esco Lead-shielded Biosafety Cabinet

Superior Protection for Radioisotope Laboratories

The **Esco Lead-shielded Biosafety Cabinet** is designed for radiopharmaceutical dispensing of generator-produced radioisotopes and dose calibration of all radioisotopes.

External Material of Construction

Choices between Esco ISOCIDE™ antimicrobial coating on electrogalvanized steel or stainless steel 304.

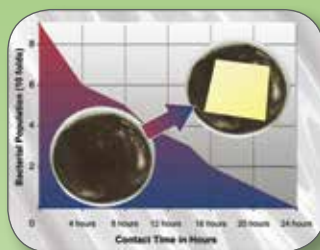

Modular Design

Modular and easily customized with your desired equipment integrated inside the workstation

Sentinel™ Gold Microprocessor

Supervises functions, visual monitoring and alarm system

Ergonomic Sloped Front

Eliminates glare off the front window, and ensures operator comfort during extended usage



5

Other key features:

- Radiation proof acrylic glass with lead equivalence
- Quiet, energy-efficient fan; motor unit auto-adjusts to compensate for filter blockage
- Interior walls are made of 316L stainless steel for maximum corrosion resistance
- With integrated dose calibrator reader out and shielded generator system

Ensured Protection from Radiation

Pb-shielding on cabinet front, sides, and work zone bottom based on client's needs and required specifications

Equipment Integration

Integrated with generator, dose calibrator, and waste container.

L-block shields feature seamless 304 brushed stainless steel exteriors



Cytoculture[®]

Lead-Shielded Class II Biosafety Cabinet

The **Esco Cytoculture[®] Lead-Shielded Class II biosafety cabinet** is designed for radiopharmaceutical handling usage and protects the operator during work involving radioisotopes.

ISOCIDE™

Esco ISOCIDE™ antimicrobial coating on all painted surfaces minimizes contamination

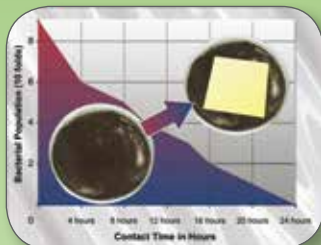

Ensured Protection from Radiation

Pb-shielding on cabinet front, sides, and work zone bottom based on client's needs and required specifications

Carbon Filter

Impregnated with potassium iodide for iodine adsorption

HEPA (H14) Filters

With typical efficiency of >99.99% for particle size between 0.1 to 0.3 microns provide ISO Class 5 cleanliness within the work zone

Esco Sentinel™ Silver Microprocessor

Supervises functions, visual monitoring and alarm system

Ergonomic Sloped Front

Eliminates glare off the front window, and ensures operator comfort during extended usage



Dual Exhaust Filters

Allows for filter-changing without prior decontamination of the cabinet

General Specifications, Cytotoxic Safety Cabinets

Note to customer: Insert electrical voltage number into last model number digit _ when ordering.

Model	LS2-4A	LS2-6A
Nominal Size	1.2 meters (4')	1.8 meters (6')
External Dimensions (W x D x H)	1420 x 780 x 2190 mm 55.9" x 30.7" x 86.2"	2030 x 780 x 2190 mm 79.9" x 30.7" x 86.2"
Internal Work Area, Dimensions (W x D x H)	1270 x 603 x 670 mm 50.0" x 23.7" x 26.4"	1870 x 603 x 670 mm 73.6" x 23.7" x 26.4"
Internal Work Area, Space	0.60 m ² (6.4 sq.ft.)	0.90 m ² (9.7 sq.ft.)
Average Airflow Velocity	Inflow	0.45 m/s (90 fpm)
	Downflow	0.30 m/s (60 fpm)
Exhaust Volume with Thimble Duct	CBV Exhaust Volume	611 m ³ /h (360 cfm)
	Static Pressure at CBV Exhaust Volume	39 Pa / 0.15 in H ₂ O
ULPA Filter Typical Efficiency	>99.999% for particle size between 0.1 to 0.2 microns	
Sound Emission Per EN 12469*	61 dBA	63 dBA
Fluorescent Light Intensity At Zero Ambient	>1300 Lux (>121 foot candles)	>1200 Lux (>111 foot candles)
Cabinet Construction	1.5 mm (0.06") 16 gauge electrogalvanized steel with Isocide white oven-baked epoxy powder-coating	
Net Weight	383 kg (844 lbs)	500 kg (1102 lbs)
Shipping Weight	403.6 kg (889.8 lbs)	476.5 kg (1050.5 lbs)
Shipping Dimensions, Maximum (W x D x H)	1570 x 940 x 2210 mm 61.8" x 37.0" x 87.0"	2150 x 950 x 2200 mm 84.6" x 37.4" x 86.6"
Shipping Volume, Maximum	3.26 m ³ (115 cu.ft)	4.49 m ³ (158.6 cu.ft)

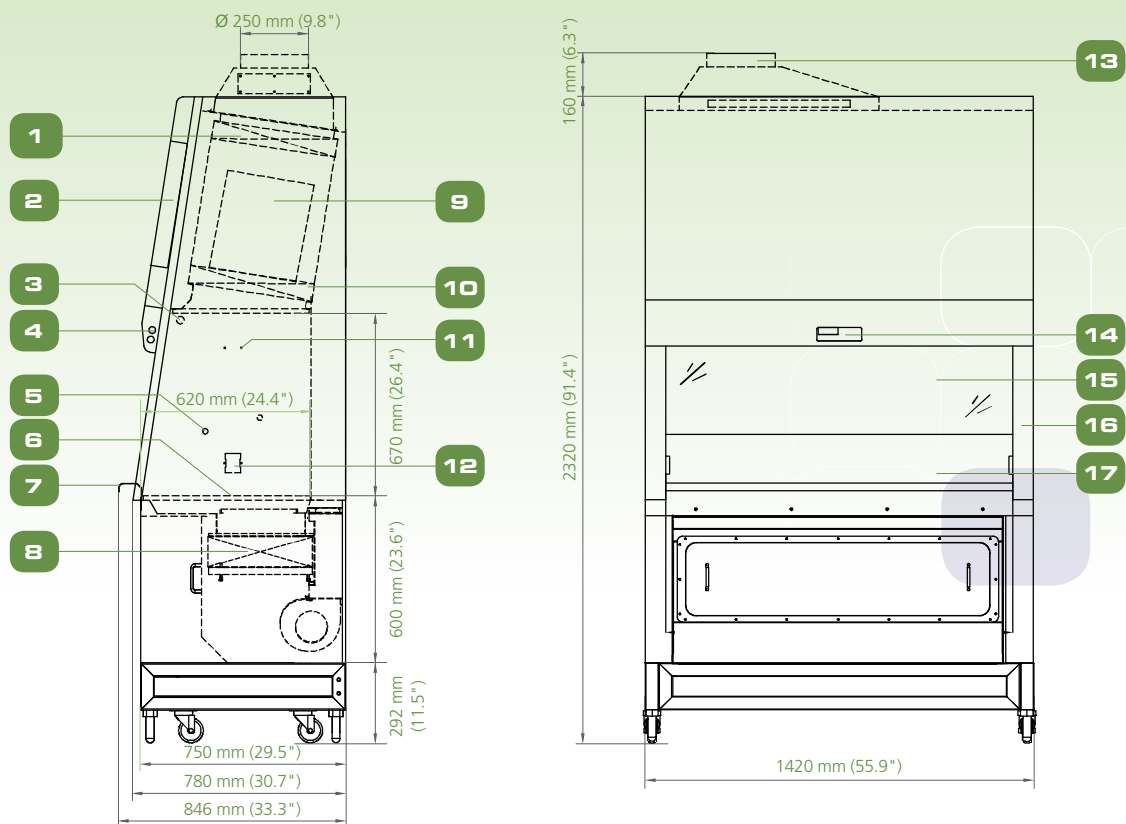

1. Exhaust ULPA filter
2. Electrical Panel
3. UV Lamp Retrofit Kit Provision
4. Fluorescent lamp
5. Service Fixture Retrofit Kit provision
6. Stainless steel multi-piece work tray
7. Stainless Steel Arm Rest

8. Exhaust ULPA filter
9. DC ECM Blower
10. Downflow ULPA Filter
11. IV Bar Retrofit VKit Provision
12. Electrical Outlet Retrofit Kit Provision (two on each side)
13. Exhaust Collar (Optional)

14. Esco Sentinel™ Silver Microprocessor Controller
15. Motorized Sash Window
16. Removable Side Panel
17. Single-piece stainless steel back wall and side walls

Radioisotope Dispensing Isolator

Safe Handling of Radiopharmaceuticals

The **Technetium Dispensing Isolator** is designed to provide safe, controlled, and sterile environment for elution and dispensing of Technetium-radiolabeled pharmaceuticals. It is configured to operate at a negative pressure in a single pass airflow. It provides a comprehensive personnel and product protection.

Grade A/ ISO Class 5 environment

Isolator chamber comes with HEPA (H14) filter that provides the necessary environment conditions for sterile product handling



Energy-efficient ECM Motor

Quiet, energy-efficient ECM fans auto adjust to compensate for filter blockage

Pressure Decay Test

- Capable of carrying out Pressure Decay Test to check for the presence of leaks
- Pressure-tested to Class 3 as per ISO 10648-2 standards

Sentinel™ Microprocessor

Supervises functions, visual monitoring and alarm system

Dose calibrator and Generator

Integrated with dose calibrator and generator compartments

Other key features:

- Air of each enclosure is equipped HEPA (H14) filters with 99.995% providing ISO Class 5 (Grade A) environment to ensure product protection
- Constructed with powder-coated electrogalvanized steel exteriors and 316L stainless steel interiors
- Generators are housed in a Pb-shielded compartment with lift for easy handling
- Dose calibrator compartment set-up, console set-up on the front side
- Shielded waste compartment set-up
- Fully sealed and interlocked doors on all chambers
- Audible and visual alarms

Other Radiation Shielding Components

Shielded compartments for generator, dose calibrator and waste container with customizable lead-shielding thickness

Lead-shielded Protection

Radiation proof acrylic glass with oval glove ports and work zones with Pb



GMP-compliant Radioisotope Dispensing Isolator

Aseptic preparation and dispensing of radiopharmaceuticals

The **GMP-compliant Radioisotope Isolator** is designed for the aseptic elution and dispensing of generator-produced radioisotopes, such as Tc-99m and Ga-68. It is configured to operate at a negative pressure in a single pass airflow. It provides a comprehensive personnel and product protection.

PIC/S and GMP Compliant

Complete design compliance to PIC/S and GMP

Lead-shielded Compartments

With dedicated compartments for each vital process such as elution and dosing; lead-shielding is based on client's required specification

Automated Pressure Hold Test

Capable of carrying out Automated Pressure Test as per ISO 10648-2 standards



HMI/PLC Controller System

21 CFR Part 11 Compliant control system that supervises all functions, visual monitoring and alarm system of the isolator



BioVap™ Biodecontamination System

Fully automated and GMP-compliant biodecontamination system

Equipment Integration

Integrated with generator and dose calibrator

Other key features:

- Generators are housed in a Pb-shielded compartment with lift for easy handling
- Dose calibrator compartment in a dedicated dosing chamber to limit contamination and wrong dosing.
- Fully sealed and interlocked doors on all chambers
- With separate transfer chamber for ingress and egress of materials, for faster unidirectional workflow process.

Accessories

- Glove Leak Tester
- Radiation Monitoring System
- Automated BioVap™ biodecontamination system
- Relative Humidity and Temperature Monitoring in each chamber

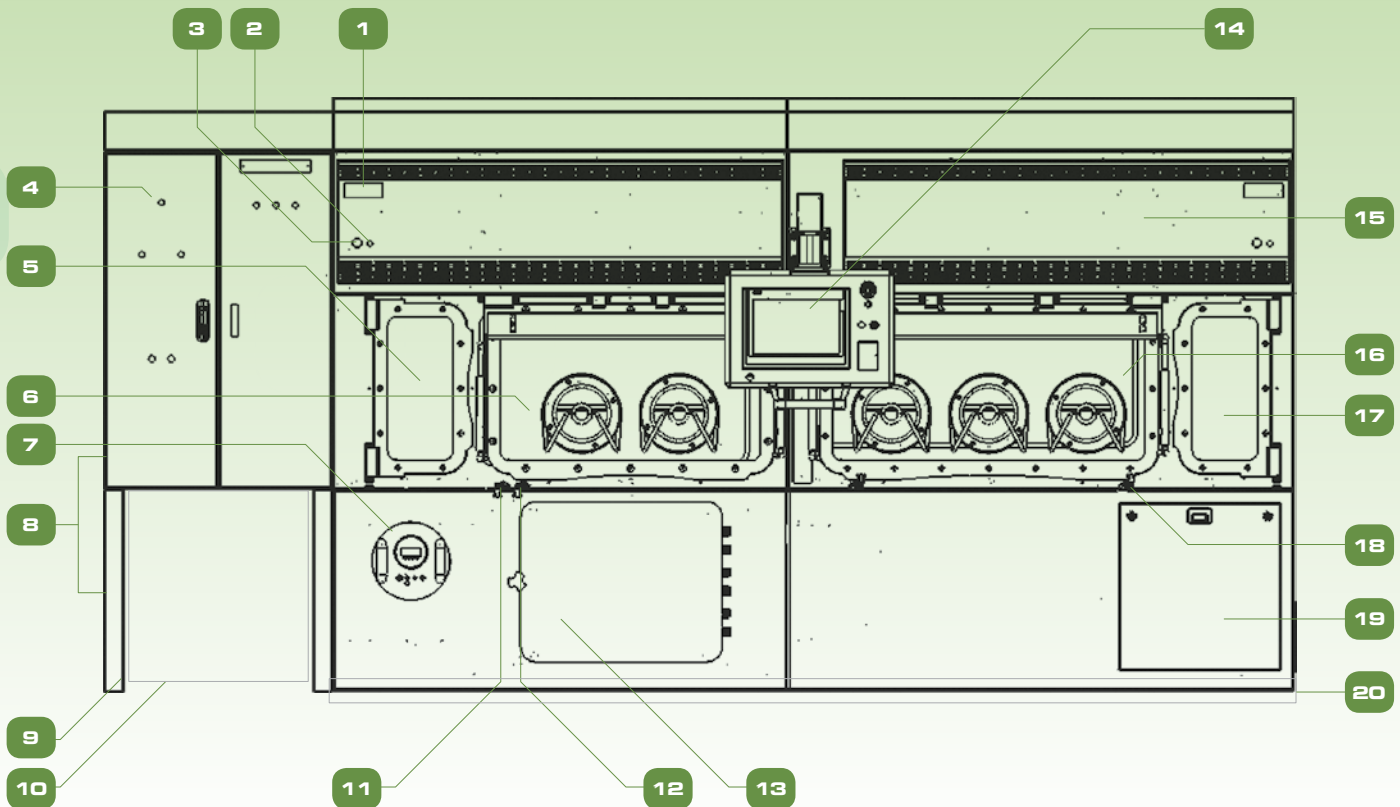

1. Signal Tower Light
2. Reset
3. Emergency
4. MCP
5. Transfer Chamber 1
6. Elution Chamber
7. Glove Leak Tester

8. Wall
9. Support Frame Cover
10. Existing Exhaust
11. Air Sampler Out
12. External Particle Counter Out
13. Generator Box
14. HMI

15. Intake Plenum Cover
16. Dosing Chamber
17. Transfer Chamber 2
18. Capintec Cable Out
19. Decon System
20. Footing Cover

PRODUCTS AND APPLICATION

Life Sciences Laboratory Equipment

Sample Preparation

- Class I Biological Safety Cabinets
- Class II Microbiological Safety Cabinets
- Class II Type A2 Biological Safety Cabinets
- Class II Type B1 Biological Safety Cabinets
- Class II Type B2 Biological Safety Cabinets
- Class III Biological Safety Cabinets
- Horizontal Laminar Flow Clean Benches
- Vertical Laminar Flow Clean Benches
- Laboratory Animal Research Workstations
- Laboratory Centrifuges

Sample Cultivation

- CO₂ Incubators, Direct Heat Air-Jacketed
- CO₂ Incubators with Cooling System
- CO₂ Incubators with Stainless Steel Exterior
- Laboratory Shakers

Sample Handling and Analysis

PCR Thermal Cyclers

- Conventional Thermal Cyclers

PCR Sample Handling

- Microplate Shakers
- PCR Cabinets

Sample Storage & Sample Protection Solutions

- Ultra-low Temperature Freezers
- Lab Refrigerators and Freezers
- Sample Database Management Software
- Intelligent Remote Monitoring Application Protocol
- Remote Monitoring, Datalogging, Programming Software
- Wireless Monitoring System

Chemical Research

- Ductless Fume Hoods
- Laboratory Fume Hoods
- Fume Hood Airflow Monitors
- Exhaust Blowers
- Powder Weighing Balance Enclosures
- Filtered Storage Cabinet

General Equipment

Laboratory Thermostatic Products

- Laboratory Oven
- Laboratory Incubator
- Refrigerated Incubator
- Natural Convection Incubator

Forensic Sciences

- Evidence Drying Cabinet

Medical / IVF Equipment

Controlled Embryo Handling

- Fertilisafe™ ART Workstation
- AVT-I Anti Vibration Table
- Semi Closed Environment IVF

Safe Embryo Culture

- MIRI® Multi room Benchtop Incubator
- CelCulture® CO₂ Incubator
- Mini MIRI® Humidified Benchtop Incubator

Innovative Time Lapse Imaging

- MIRI® Time-lapse Incubator

Accurate Quality Control

- MIRI® GA Gas and Temperature Validation Unit
- MIRI® GA Mini Gas Validation Unit

Unique Consumables

- CultureCoin

Healthcare

Esco Pharma Products

Airflow Containment Products

- Pharmacon® Downflow Booths
- Ceiling Laminar Airflow Units
- Laminar Flow Horizontal/Vertical Trolley
- Enterprise™ Laminar Flow Straddle Unites
- Cytoculture™ Cytotoxic Safety Cabinets

Isolation Containment

- Aseptic Containment Isolator (ACTI)
- Weighing and Dispensing Containment Isolator (WDCI)
- General Processing Platform Isolator (GPPI)
- Containment Barrier Isolator (CBI)
- Turbulent Flow Aseptic (Grade A) Isolator (TFAI)
- Isoclean® Healthcare Platform Isolator (HPI)
- Streamline® Compounding Isolators (SCI)
- Technetium Dispensing Isolators
- Blood Cell Labeling Isolators
- Open and Closed Restricted Barrier Access Systems (RABS)

Cross Contamination Facility Integrated Barrier

- BioPass™ Pass Through
- Infinity® Air Shower Pass Box
- Cleanroom Air Shower
- Infinity® Cleanroom Transfer Hatch
- Infinity® Pass Box
- Soft capsule® Soft Wall Cleanroom
- Dynamic Passboxes and Dynamic Floor Laminar Hatches
- Laminar Flow Storage Cabinet

Ventilation Containment

- Ventilated Balance Enclosure

VacciXcell Products

Bioreactors and Fermenters

- CelCradle™
- TideXcell™
- VacciXcell™ Hybrid Bioreactor

Cell Culture Monitoring, Media and Consumables

- Super Plus™
- Plus™ Vero
- Plus™ MDCK
- Plus™ MDCK II
- BioNOC™ II macrocarriers
- GlucCell™ Glucose Monitoring System
- CVD Kit

Filling Line Equipment

- Filling Line Isolators
- cRabs (close restricted access barriers)
- oRabs (open restricted access barriers)

Integrated Solutions

- Cell Processing Isolator
- Cell Processing Center

TaPestle Rx Products and Services

PRODUCTS

- Pharmacy Automation and Compounding Supply
- Compounding Pharmacy Isolators (SCI, HPI, CBI, GPPI)
- Safety Cabinets and Enclosures (Class II BSC, VBE, LFC)
- Radiopharmacy Hoods and Isolators
- Aseptic Filling Systems

Healthcare and Laboratory Construction Components

- Prefabricated Walls (Airecell®)
- Prefabricated Containerized Facility (Prefab™)
- Series Ceiling Systems
- Hygienic/Hermetic Door Systems
- Surgical Scrub Sinks
- Vinyl Tiles and Epoxy
- Laboratory Fit-outs
 - Worktops
 - Frames
 - Specialty Storage cabinets
 - Service Spines & Reagent Shelving

SERVICES

- Conceptualization
- Planning
- Procurement
- Installation

FACILITY DESIGNS

- Process Architecture
- Biocontainment/Biosafety
- Pharmacy Compounding/Nuclear Medicine
- Cleanroom, Vaccine and Cell Processing
- Laboratory
- Containerized Facility
- ART/IVF
- Cold Chain

ESCO GLOBAL NETWORK

43 Locations In 23 Countries All Over The World

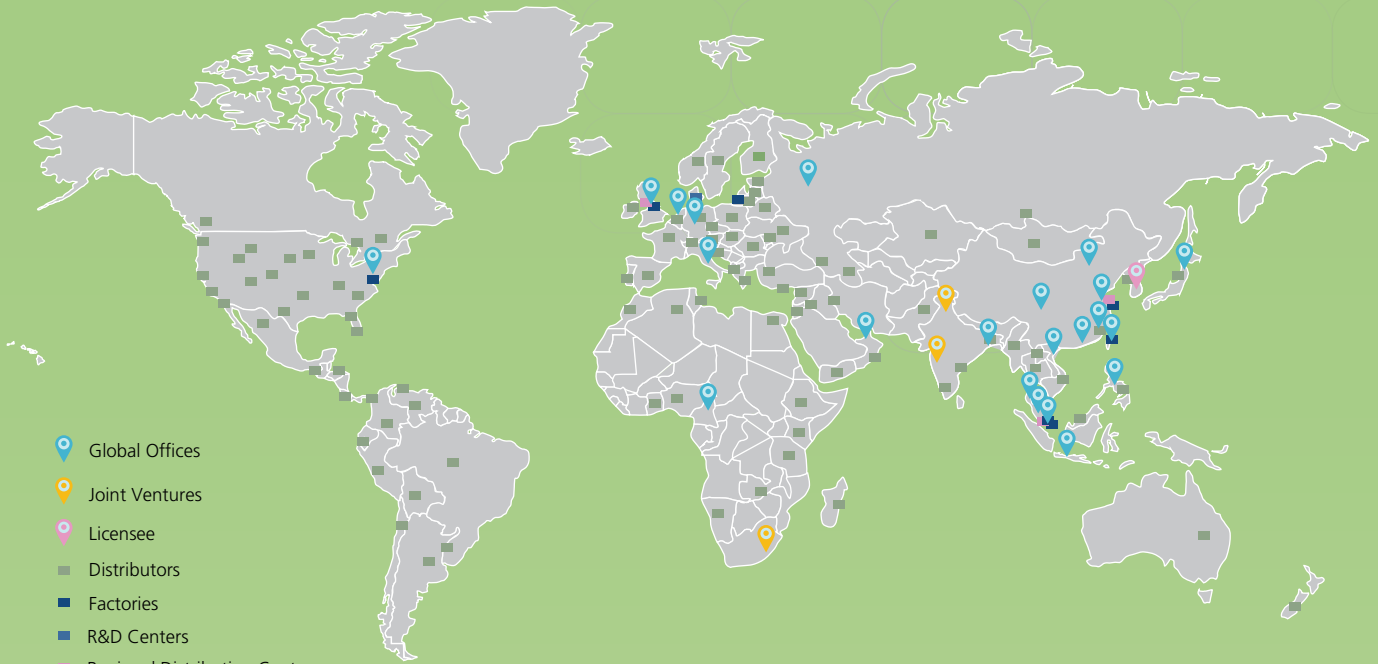

- Air Shower
- Aseptic Containment Isolator (ACTI)
- Ceiling Laminar Airflow Units
- Cleanroom Transfer Hatch
- Containment Barrier Isolator (CBI)
- Downflow Booth (DFB)
- Dynamic Floor Label Hatch
- Dynamic Pass Box
- Evidence Drying Cabinet
- Garment Storage Cabinet
- General Processing Platform Isolator (GPPI)
- Laminar Flow Horizontal Trolley
- Laminar Flow Straddle Units, Single and Double
- Laminar Flow Vertical Trolley
- Pass Box
- Soft Wall Cleanroom
- Sputum Booth
- Ventilated Balance Enclosure (VBE)
- Weighing and Dispensing Containment Isolator (WDCI)

Since 1978, Esco has emerged as a leader in the development of controlled environment, laboratory and pharmaceutical equipment solutions. Products sold in more than 100 countries include biological safety cabinets, fume hoods, ductless fume hoods, laminar flow clean benches, animal containment workstations, cytotoxic cabinets, hospital pharmacy isolators, and PCR cabinets and instrumentation. With the most extensive product line in the industry, Esco has passed more tests, in more languages, for more certifications, throughout more countries than any biosafety cabinet manufacturer in the world. Esco remains dedicated to delivering innovative solutions for the clinical, life science, research and industrial laboratory community. www.escoglobal.com.



Esco Pharma Pte Ltd
 21 Changi South Street 1 Singapore 486777 • Tel: +65 65420833
 Fax: +65 65426920 • Email: csis.pharma@escoglobal.com

Esco Technologies, Inc.
 2512 Metropolitan Drive, Suite 120 B
 Feasterville- Trevose, PA 19053-6738
 Tel: 215 322 2155 • Email: eti.pharma@escoglobal.com

Esco Gb Ltd
 Unit 2 R-evolution @ Gateway 36, Kestrel Way, Barnsley, S70 5SZ
 Tel: +44 (0) 1226 360 799 • Email: egb.pharma@escoglobal.com

Esco Global Offices: Bangladesh | Cameroon | China | Denmark | Germany | Hong Kong | India | Indonesia | Italy | Japan | Lithuania | Malaysia | Myanmar | Philippines | Russia | Singapore | South Africa | South Korea | Taiwan | Thailand | UAE | UK | USA | Vietnam



Radipharma Compounding Equipment, A4, VA, 05202019.
 Esco can accept no responsibility for possible errors in catalogues, brochures and other printed materials.
 Esco reserves the right to alter its products and specifications without notice. All trademarks and logos in
 this material are the property of Esco and the respective companies.